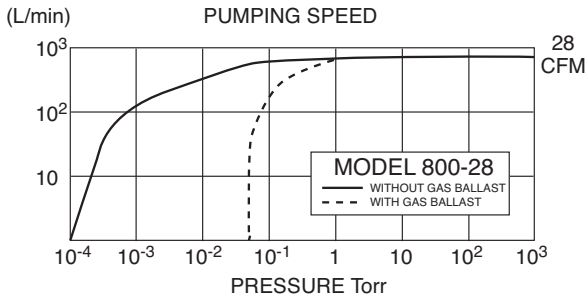
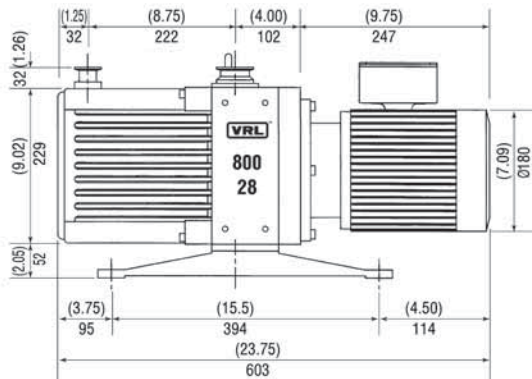



Photo shows Pump with optional inlet trap and exhaust mist eliminator installed. See page 12 to order these accessories.



Pumping Speed @ 60 Hz	800 l/min, 28 CFM, 48 m ³ /hr.
Pumping Speed @ 50 Hz	666 l/min, 23 CFM, 40 m ³ /hr.
Ultimate Pressure Gas Ballast Closed	5x10 ⁻⁴ Torr, 6.7x10 ⁻² Pa, .0006 mbar
Ultimate Pressure Gas Ballast Open	5x10 ⁻² Torr, 6.7 Pascal, .06 mbar
Standard Motor, Thermal Protection, CE Mark, complies with	230/380V, 3ø, 50/60 Hz, 2 hp Machinery directive 98/37/EC
Power Connection	Junction Box
Motor speed @ 60 Hz	1700 r.p.m.
Oil capacity	2300 cc; 2.4 Qt.
Weight Net: 117 lbs., 53 kg	Shipping: 133 lbs., 60 kg
Intake & Exhaust type or diameter	NW-40 or 36 mm O.D. Tube
Ambient operating temperature	7° to 40°C, 45° to 104°F



Features

- Extremely Quiet • Anti Suck Back Design
- Satisfaction Guaranteed • Two Year Warranty
- Virtually Vibration Free • Motors for Any Voltage
- Complies with Machinery Directive 98/37/EC

Applications

- Backing Turbo Pumps • Electron Microscopes
- Vacuum Ovens & Furnaces • Freeze Dryers
- Cluster Tool Load Locks • Sputter & Deposition Systems

Typical Installation

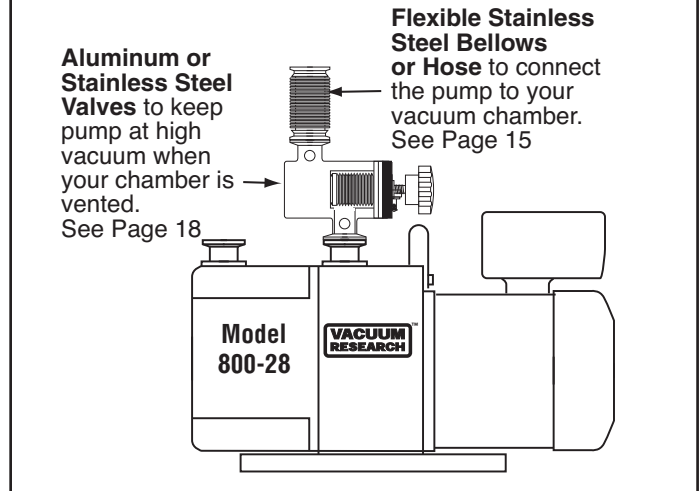

Ordering Information

MODEL 800-28 Vacuum Pump With Motor:

- 230 or 460V, 60 Hz, 3ø, 1.5 kw (2 hp)
Full load current 6.0 or 3.0 Amps
p/n 800-CE-230-460-60 \$4980.
 - 220 or 380V, 50/60 Hz, 3ø, 1.5 kw (2 hp)
Full load Current @ 50 Hz; 6.5 or 4 A @60 Hz; 6.0 or 3.6 A
p/n 800-CE-380-50/60 \$4980.
 - 208 or 380V, 50 Hz, 3ø, 1.5 kw (2 hp)
Full load current: 7.2 or 4.0 Amps
p/n 800-CE-380-50 \$4980.
- Pumps with motors for other voltages and single phase power also available. Please contact the factory for price and availability.

Exhaust Mist Eliminators

- Exhaust Filter** Coalescing filter for exhaust mist elimination. 99.97% removal efficiency of droplets down to 0.3 micron diameter. Model EX.FIL, NW-40, 28 cfm
p/n RV810240 \$345.