

WELDED ALUMINUM POPPET VALVES SHIPPED 2000 AND BEFORE

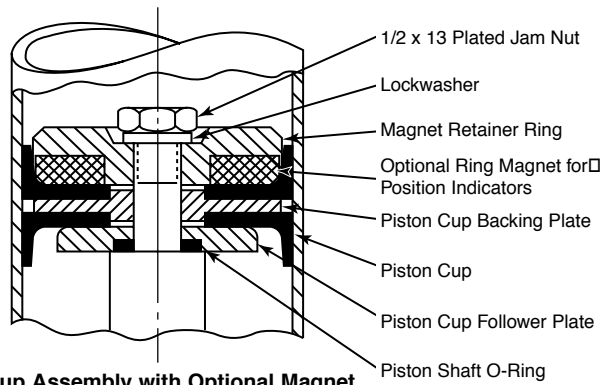

Piston Cup Assembly with Optional Magnet for Valves with Position Indicators

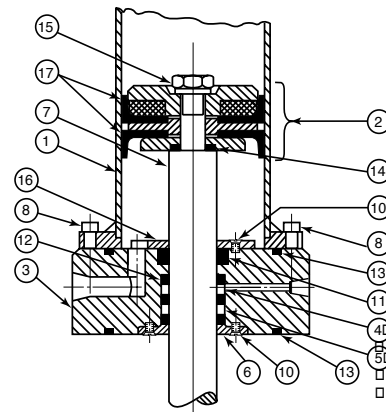

Spare Parts For Welded Aluminum Poppet Valves			2AV	3AV	4AV	6AV	10AV
Item	Qty.	Description	(pn/price)	(pn/price)	(pn/price)	(pn/price)	(pn/price)
1	1	Air Cylinder Weldment	X2AV01 81.00	X2AV01 81.00	X4AV01 87.00	X6AV01 98.00	X10AV01 87.00
2	1	Piston Cup Assembly	X2AV02 101.00	X3AV02 101.00	→		
3	1	Seal Housing	X2AV03 111.00	X2AV03 111.00	X4AV03 125.00	X6AV03 162.00	X10AV03 305.00
4	1	Seal Pump Out Spacer	X2AV04 4.95	X2AV04 4.95	→		
5	1	Seal Spacer	X2AV05 2.50	X2AV05 2.50	X2AV05 2.50	X2AV05 2.50	X2AV05 2.50
6	1	Lower Seal Retainer	X2AV06 55.00	X2AV06 55.00	X2AV06 55.00	X2AV06 55.00	X2AV06 55.00
7	1	Actuating Shaft	X2AV07 138.00	X3AV07 138.00	X4AV07 148.00	X6AV07 176.00	X10AV07 194.00
8	8	Cylinder Retaining Screws, Four (4) 1/4 -20 x 2 1/2 Long Steel Socket Head Cap and Four (4) 4 -20 x 3/4 Long Steel Socket Head Cap Screws (price per set of 8)	X2AV08 3.50	→			
10	8	10/32 x 3/8 Long Steel Flat Head Cap Screws for top & bottom Seal Retainers (per set of 8)	X2AV10 1.00	X2AV10 1.00	X2AV10 1.00	X2AV10 1.00	X2AV10 1.00
11	1	Actuating Shaft Wiper Seal	X70118700625 6.00	X70125001000 6.00	X70125001000 6.00	X70125001000 6.00	X70125001000 6.00
12	3	Shaft Seal Rings (per set of 3)	X701Q4208 2.50	X701Q4214 2.50	X701Q4214 2.50	X701Q4214 2.50	X701Q4214 2.50
13	2	Seal Housing O-Ring	X701227B 1.00	X701236B 1.00	→		
14	1	Piston Shaft O-Ring	X701110B 1.00	X701206B 1.00	→		
15	1	1/2-13 Steel Hex Jam Nut	X2AV15 1.00	X2AV15 1.00	X2AV15 1.00	X2AV15 1.00	X2AV15 1.00
16	1	Top Seal Retainer	X2AV16 46.00	→			
17	2	Piston Cup (price each, 2 required)	X7012000500 18.00	X7013000625 18.00	→		
N/A	1	Split Clamp for Shaft Seal Plate Connection	X2AV124 46.00	→			
N/A	1	Bonnet Plate Sintered Bushing	2AV300 18.00	→			
N/A	1	O-ring Kit, Buna-N	X701305B 54.00	X701306B 74.00	X701406B 79.00	X701606B 81.00	X7011006B 101.00