

Two Stage Rotary Vane Vacuum Pumps Operation and Maintenance Manual



Model 800 – 28
800 l/min. • 28 CFM • 48 m³/hr.



Model 600 – 21
600 l/min. • 21 CFM • 36 m³/hr.



Model 400 – 14
400 l/min. • 14 CFM • 24 m³/hr.



Model 200 – 7
200 l/min. • 7 CFM • 12 m³/hr.



Model 100 – 3.5
100 l/min. • 3.5 CFM • 6 m³/hr.

Pumps are shown with optional inlet traps and exhaust mist eliminators. See page 12 in the Rotary Vane Vacuum Pumps Catalog or contact the factory to order these accessories.

Contents

FORWARD	2
WARNINGS	3
PUMP SPECIFICATIONS AND PUMP SPEED CURVES	4
PREPARING AND INSTALLING THE PUMP	7
RECEIVING	7
REPORTING SHIPPING SHORTAGE	7
REPORTING INCORRECT SHIPMENT	7
INITIAL FILLING WITH VACUUM PUMP FLUID	8
CONNECTING THE PUMP TO THE SYSTEM	8
STARTING AND OPERATING THE PUMP	9
START UP	9
OPERATION	10
ANTISUCKBACK	10
GAS BALLAST	10
MAINTAINING THE PUMP	11
PREVENTATIVE MAINTENANCE	11
TROUBLESHOOTING	14
DIMENSIONS	15

Forward

This manual contains installation, operation, maintenance, and troubleshooting information for the Model 100-3.5, Model 200-7.0, Model 400-14, Model 600-21, and Model 800-28 Rotary Vane Vacuum Pumps. Please read it in its entirety before operating the pump.

Our Rotary Vane Vacuum Pumps are designed to ensure safety when used properly. It is the responsibility of the user to follow safety-related warnings, cautions, notes, and other requirements described in this manual.

Returned equipment will not be accepted by our company without prior authorization. Prior to shipping please call for a returned goods authorization number (RGA).

We reserve the right to cancel the warranty if the pump is disassembled without authorization, if pump fluids are used that are not compatible with the design and materials used in the manufacture of the pump, and if unauthorized spare parts are used.

WARNINGS

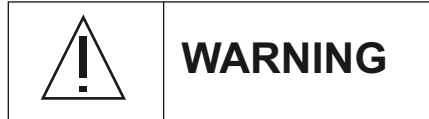

Death or serious injury can result from improper use or application of this pump. If the pump will be exposed to toxic, explosive, pyrophoric, highly corrosive, or other hazardous process gases including greater than atmospheric concentrations of oxygen, contact the manufacturer for specific recommendations.

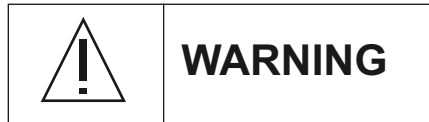

Ground the motor properly during installation. Disconnect the power before beginning installation, maintenance or repair work or before interchanging the input leads when correcting the direction of rotation. Disconnecting the power also avoids an unexpected start-up for pumps with automatically resetting thermal overloads.

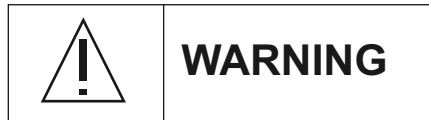

Don't run the pump without an exhaust line and an adequate exhaust system if hazardous gases or vapors are expelled from the pump. Don't exceed a maximum backpressure of 7 psig. Excessive pressure in the pump could damage the seals, blow out the sight glass, or rupture the pump housing. In addition, excessive backpressure can result in hazardous process gas or contaminated oil leaking out of the pump. Don't install an exhaust line with a smaller ID than the exhaust port or allow restrictions or deposit build up in the exhaust line. If you are purging the oil casing with inert gas, limit the inert gas flow to avoid exceeding the 7 psig limit. Accidentally connecting the pump's exhaust port to a vacuum line containing a closed valve also causes a dangerous excessive pressure.

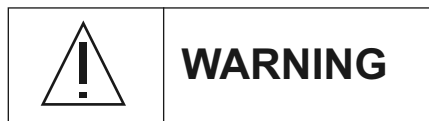

Hazardous process gases can concentrate in the vacuum pump, its oil, and its filters. If the pump has been used on toxic, explosive, pyrophoric, corrosive, volatile, or other hazardous substances, take the proper safety precautions before opening the pump or filters. Proper precautions could include inert gas purging before and after you drain the oil to sweep hazardous gas from the pump or filters; wear gloves or protective clothing to avoid skin contact with toxic or highly corrosive substances; specially ventilated work areas; fume hoods; safety masks; breathing apparatus; etc.

PUMP SPECIFICATIONS AND PUMP SPEED CURVES

Specifications: Model 100-3.5	Pump Speed Curve
<p>Pumping Speed @ 60 Hz.....100 l/min, 3.5 CFM, 6 m³/hr. @ 50 Hz.....83 l/min, 3 CFM, 5 m³/hr.</p> <p>Ultimate Pressure Gas Ballast Closed.....5x10⁻⁴ Torr, 6.7x10⁻² Pa, .0006 mbar Gas Ballast Open.....5x10⁻² Torr, 6.7 Pascal, .06 mbar</p> <p>Standard Motor, CE Marked.....115/208-230V, 1ø, 1/2 hp, 60 Hz Includes On/Off Switch and Circuit Breaker (50 Hz available)</p> <p>Optional Motor, CE Marked.....115/208-230V, 50/60 Hz, 1ø, 1/2 hp 220-240V, 50 Hz, 1ø, 1/2 hp</p> <p>Power connection6 foot (2 m) 3 conductor cord</p> <p>Motor speed @ 60 Hz.....1700 r.p.m.</p> <p>Oil capacity.....500 cc; 0.53 Qt.</p> <p>Weight Net: 50 lbs., 23 kgShipping: 54 lbs., 24 kg.</p> <p>Intake & exhaust type/diameter...NW-25 or 26 mm O.D. Tube</p> <p>Ambient operating temperature...7° to 40°C, 45° to 104°F</p> <p>Overall dimensions.....150 (W) x 398 (L) x 251 (H) mm</p> <p>Overall dimensions.....5.9 (W) x 15.7 (L) x 9.9 (H) Inches</p>	

Specifications: Model 200-7	Pump Speed Curve
<p>Pumping Speed @ 60 Hz.....200 l/min, 7.0 CFM, 12 m³/hr. @ 50 Hz.....166 l/min, 5.8 CFM, 10 m³/hr.</p> <p>Ultimate Pressure Gas Ballast Closed.....5x10⁻⁴ Torr, 6.7x10⁻² Pa, .0006 mbar Gas Ballast Open.....5x10⁻² Torr, 6.7 Pascal, .06 mbar</p> <p>Standard Motor, CE Marked.....115/208-230V, 1ø, 1/2 hp, 60 Hz Includes On/Off Switch and Circuit Breaker (50 Hz available)</p> <p>Optional Motor, CE Marked.....115/208-230V, 50/60 Hz, 1ø, 1/2 hp 220-240V, 50 Hz, 1ø, 1/2 hp 220-380V, 3ø, 50/60 Hz, 1/2 hp</p> <p>Power connection6 foot (2 m) 3 conductor cord</p> <p>Motor speed @ 60 Hz.....1700 r.p.m.</p> <p>Oil capacity.....600 cc; 0.62 Qt.</p> <p>Weight Net: 53 lbs., 24 kgShipping: 57 lbs., 26 kg.</p> <p>Intake & exhaust type/diameter...NW-25 or 26 mm O.D. Tube</p> <p>Ambient operating temperature...7° to 40°C, 45° to 104°F</p> <p>Overall dimensions.....150 (W) x 434 (L) x 251 (H) mm</p> <p>Overall dimensions.....5.9 (W) x 11.1 (L) x 9.9 (H) Inches</p>	

Specifications: Model 400-14

Pump Speed Curve

Pumping Speed

- @ 60 Hz.....400 l/min, 14 CFM, 24 m³/hr.
- @ 50 Hz.....333 l/min, 11.6 CFM, 20 m³/hr.

Ultimate Pressure

- Gas Ballast Closed.....1x10⁻³ Torr, 0.13 Pa, .001 mbar
- Gas Ballast Open.....5x10⁻² Torr, 6.7 Pascal, .06 mbar

Standard Motor, CE Marked.....230/380V, 3ø, 50/60 Hz, 1 hp

Optional Motor.....230/380V, 3ø, 50/60 Hz, 1 hp
230/460V, 3ø, 60 Hz, 1 hp

Power connectionJunction Box

Motor speed @ 60 Hz.....1700 r.p.m.

Oil capacity.....1500 cc; 1.5 Qt.

Weight Net: 70 lbs., 32 kgShipping: 75 lbs., 34 kg.

Intake type/diameter.....NW-25 or 26 mm O.D. Tube

Ambient operating temperature...7° to 40°C, 45° to 104°F

Overall dimensions.....147 (W) x 230 (L) x 216 (H) mm

Overall dimensions.....5.79 (W) x 17.08 (L) x 8.5 (H) Inches

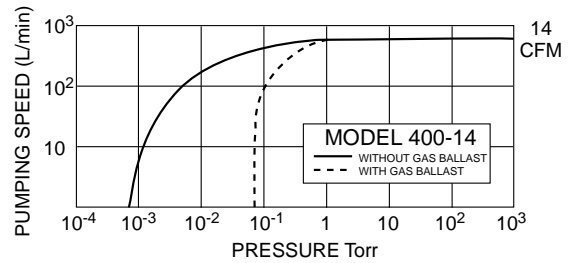

Specifications: Model 600-21

Pump Speed Curve

Pumping Speed

- @ 60 Hz.....600 l/min, 21 CFM, 36 m³/hr.
- @ 50 Hz.....500 l/min, 17.5 CFM, 30 m³/hr.

Ultimate Pressure

- Gas Ballast Closed.....5x10⁻⁴ Torr, 6.7x10⁻² Pa, .0006 mbar
- Gas Ballast Open.....5x10⁻² Torr, 6.7 Pascal, .06 mbar

Standard Motor, CE Marked.....230/380V, 3ø, 50/60 Hz, 2 hp

Optional Motor.....220/380V, 3ø, 50 Hz, 2 hp, CE
230/460V, 3ø, 60 Hz, 2 hp, CE

Power connectionJunction Box

Motor speed @ 60 Hz.....1700 r.p.m.

Oil capacity.....2700 cc; 2.9 Qt.

Weight Net: 114 lbs., 52 kgShipping: 130 lbs., 59 kg.

Intake type or diameter.....NW-40 or 36 mm O.D. Tube

Exhaust type or diameter.....NW-40 or 36 mm O.D. Tube

Ambient operating temperature...7° to 40°C, 45° to 104°F

Overall dimensions.....206 (W) x 645 (L) x 315 (H) mm

Overall dimensions.....8.1 (W) x 25.4 (L) x 12.4 (H) Inches

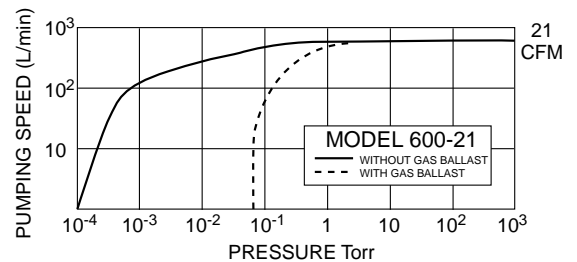

Specifications: Model 800-28

Pump Speed Curve

Pumping Speed

- @ 60 Hz.....800 l/min, 28 CFM, 48 m³/hr.
- @ 50 Hz.....666 l/min, 23 CFM, 40 m³/hr.

Ultimate Pressure

- Gas Ballast Closed.....5x10⁻⁴ Torr, 6.7x10⁻² Pa, .0006 mbar
- Gas Ballast Open.....5x10⁻² Torr, 6.7 Pascal, .06 mbar

Standard Motor, CE Marked.....230/380V, 3ø, 50/60 Hz, 2 hp

Optional Motor.....220/380V, 3ø, 50 Hz, 2 hp, CE
 230/460V, 3ø, 60 Hz, 2 hp, CE

Power connectionJunction Box

Motor speed @ 60 Hz.....1700 r.p.m.

Oil capacity.....2300 cc; 2.4 Qt.

Weight Net: 117 lbs., 53 kgShipping: 133 lbs., 60 kg.

Intake type or diameter.....NW-40 or 36 mm O.D. Tube

Exhaust type or diameter.....NW-40 or 36 mm O.D. Tube

Ambient operating temperature....7° to 40°C, 45° to 104°F

Overall dimensions.....206 (W) x 645 (L) x 315 (H) mm

Overall dimensions.....8.1 (W) x 25.4 (L) x 12.4 (H) Inches

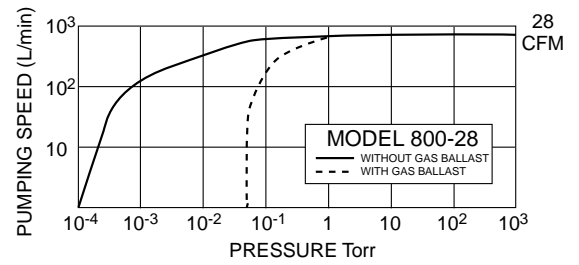

PREPARING AND INSTALLING THE PUMP

RECEIVING

Each Rotary Vane Vacuum Pump is inspected and carefully packed prior to shipment. Inspect it after carefully unpacking it. In case of external damage, retain the shipping container and notify the shipping agency and our company immediately. Because the packing materials are designed specifically for this pump, they should always be used when transporting the pump.

Unpack the pump and check for shipping damage as follows:

1. Inspect the outside of the shipping container for shipping damage. If you will be making a damage claim, save the shipping container and packing materials.
2. Unpack the pump.
3. Carefully inspect the pump for damage.
4. If you find any damage, proceed as follows:
 - a. Save the shipping container, packing material, and parts for inspection.
 - b. Notify the carrier that made the delivery within 7 days of delivery.
 - c. File a claim with the carrier.
 - d. Contact the manufacturer to make arrangements for replacing the damaged part(s).

REPORTING SHIPPING SHORTAGE

If you did not receive all the goods that you ordered, do the following:

1. Check the number of items listed on the packing slip. If the number of pieces listed is greater than the number of shipping containers received, contact the carrier concerning the missing piece.
2. Check the packing list to see if the missing item is on back order.
3. Carefully check the packing material and container to ensure that you did not overlook the missing item.
4. If you cannot find item, please notify the manufacturer or your distributor immediately.

REPORTING INCORRECT SHIPMENT

If the item received is not the item ordered, contact the manufacturer or your distributor

INITIAL FILLING WITH VACUUM PUMP FLUID

All our Rotary Vane Vacuum Pumps are shipped with a full change of vacuum pump fluid.

Always be sure that the oil level is approximately in the middle of the low and high level marks in the sight glass and please note that upon start up of the pump, the oil level in the sight glass will drop slightly.

CONNECTING THE PUMP TO THE SYSTEM

KF clamps and centering rings are supplied for the intake and exhaust ports of the pump.



CAUTION! Do not connect power to your pump until the blank off plate is removed from the exhaust port. Operating the pump with the exhaust port blanked off will damage the pump and can injure the operator.

Our company also has a complete line of components, fittings, and adapters to connect your pump to any system.

All connections must be vacuum tight for your pump to achieve its ultimate pressure. The O-ring on the centering ring must be clean to avoid leaks. Be sure that all quick release clamps are in place and properly tightened.

Connect The Pump To The System As Follows:

1. Set the pump on an even horizontal surface. It need not be permanently mounted on the surface.



CAUTION: FAILURE TO REMOVE THE EXHAUST PORT COVER BEFORE STARTING THE PUMP COULD RESULT IN DAMAGE TO THE PUMP.



WARNING: Ensure that your vacuum line is connected to the pump's intake port and not to the exhaust port. If your vacuum line has a closed valve, accidentally connecting it to the pump's exhaust port causes a dangerous overpressure.

NOTE: Ideally, the inside diameter of the vacuum line should be the same size or larger than the (ID) of the intake port. If the vacuum line is too narrow, it will reduce the pumping speed.



WARNING: Don't install an exhaust line with a smaller ID than the exhaust port

2. If possible, install the exhaust line at a slightly descending angle to prevent condensate from flowing back into the pump and contaminating the pump's vacuum fluid.
3. If the exhaust line must be installed in the ascending position and the process gas contains high levels of condensable vapors, connect a condensate trap to the exhaust port. Condensate traps serve to collect the condensates from saturated vapors. Contact your distributor for more information on the correct trap for your pump.
4. If no exhaust line is connected and your pump will be running above one (1) Torr inlet pressure, connect an exhaust mist eliminator to the exhaust port to remove pump fluid vapors and smoke. Contact us for more information on exhaust mist eliminators.
5. If the exhaust line is attached to a negative pressure exhaust system, adjust the negative pressure so that the vacuum pump fluid will not be drawn from the pump.

STARTING AND OPERATING THE PUMP

START UP

Before starting the pump, please complete the following checklist:

 **CAUTION!** Do not connect power to your pump until the blank off plate is removed from the exhaust port. Operating the pump with the exhaust port blanked off will damage the pump and can injure the operator.

1. Be sure that the pump is filled with the appropriate amount of vacuum fluid.
2. Be sure that all electrical connections have been properly wired and that there are no bare wires that could cause an electrical shock or fire.
3. Be sure that the rotation of the pump is correct. You will find a rotational arrow on the front of the motor.
4. Be sure that all system connections have been secured with the appropriate seal rings and clamps.



WARNING: IF YOUR PUMP HAS BEEN PREPARED FOR OXYGEN SERVICE, BE SURE TO SEE IF AN EXPLOSION PROOF MOTOR IS REQUIRED.

OPERATION

1. Periodically check the vacuum fluid level in the sight glass to be sure it is between the low and high levels. If you are operating the pump with the gas ballast open, it will be necessary to check the oil level more frequently.
2. If the vacuum fluid within the pump becomes discolored or contaminated, change the fluid as soon as possible. Operating the pump with contaminated or dirty oil will greatly reduce the life expectancy of the pump and may lead to the cancellation of the warranty.

ANTISUCKBACK

If the pump stops with the inlet under vacuum the antisuckback system will stop air or oil leakage inside the module or into the vacuum chamber. The vacuum integrity is guaranteed by:

- Quality of machining from surfaces between the functional elements (stator, plates, housing, etc.)
- The exhaust valves on the exhaust orifice.
- A spring valve automatically closes the oil injection canal in the pump. When the pump stops, the oil pump exhaust pressure is decreased and a spring activated valve closes the oil injection canal.

GAS BALLAST

When condensable vapors (such as water vapor) are being pumped the gas is compressed beyond its saturated pressure and can condense, impairing pump performance. The vapor pressure of water at typical pump temperatures is over 100 Torr. Even small amounts of water in the pump fluid will have a big effect on pump performance. The gas ballast control button allows a quantity of air to be injected into the second stage of the pump during “compression” to reduce the partial pressure of the pumped gas below its saturated vapor pressure and thus prevent condensation.

At the end of “compression” the pressure in the discharge chamber is greater than atmospheric. The antisuckback feature described above prevents gas and oil from being discharged into the environment.

The saturated vapor pressure of pump fluid and the condensed vapors such as water is higher when it is hot than when it is cold; therefore it is necessary to wait until the pump reaches its operating temperature before pumping condensable vapor. Using the gas ballast increases the ulti-

MAINTAINING THE PUMP

PREVENTIVE MAINTENANCE

Pump Fluid

Every vacuum pump is designed to work best with a specific pump fluid and the fluid is an active part of the pumping mechanism. For best performance from your pump, care must be used to select fluid with the physical and chemical properties engineered for your pump. For our pumps the ideal fluid for general purpose pumping is VPO-3000. This is a moderately priced fluid that is engineered to give best vacuum and longest life in our pumps. Other fluids may give performance that is good enough for your needs but our specifications are based on regular use of VPO-3000.

VPO-3000 Typical Data		
Density, lbs. / USG 60 °F	D1298	7.22
Color, ASTM	D1500	<0.5
Flash Point °F	D92	421
Viscosity cSt @ 40°C cSt @ 100°C	D445	46.6 6.97
Viscosity SUV @ 100°C SUV @ 210°C	D445/D2161	240 50
Viscosity Index	D2270	106
Pour Point, °F	D97	0
Emulsion Characteristics Distilled Water @ 130°F ML of water separated (minutes)	D1401	40 (5)
Aniline Point, °F	D611	228
UV Absorptivity (250 mm)	D2008.A4	<0.1

Checking the pump fluid level:

NOTE: When the pump is not running, the pump fluid level appears lower.

NOTE: It is not unusual for the pump fluid to foam because of the churning action within the pump. Foaming is more pronounced at higher operating pressures. If only foam is visible in the sight glass, it means that the pump fluid level is low.

Changing the pump fluid



WARNING: IF THE PUMP HAS BEEN USED ON CORROSIVE, TOXIC, OR VOLATILE CHEMICALS, OBSERVE PROPER SAFETY PRE-CAUTIONS BEFORE REMOVING THE DRAIN PLUG.



CAUTION: Hydrocarbon pump fluid should be changed at the following times:

1. After a 100 hour break-in period of pump operation.
2. When the pump fluid becomes contaminated.
3. When condensation in the pump fluid is present.
4. Before and after the pump has been stored for a long period of time.
5. Perfluoropolyether fluid should be reconditioned when it becomes contaminated.

NOTE: Always change the pump fluid while the pump is warm to prevent condensables, such as water, from remaining in the pump.

Turn the pump off and change the fluid as follows:

1. Drain the fluid from the pump. Use your fingers to remove the oil fill cap and the oil drain plug from the pump; allow the fluid to drain into a suitable container. If the fluid fill cap or fluid drain cap cannot be loosened with your fingers, cover them with a cloth and use pliers.
2. After the oil flow diminishes, switch **ON** the pump, allow it to run for about 10 seconds and then switch it **OFF**.
3. If the fluid drained from the pump is discolored, contains particulate, has a foul odor or is very dirty, flush out the pump using the procedure below until the drained fluid is clean. If your pump requires more than 2 flushes, a foreline trap or oil filtration unit should be installed on the pump. Contact the manufacturer or your distributor for more information on foreline traps and oil filtration units.
 - a. Reinstall the fluid-drain plug with flat gasket into the fluid-drain port.
 - b. Refill the pump with VPO-3000 vacuum pump fluid until the fluid level is visible in the lower rim of the fluid sight glass.
 - c. Reinstall the fluid-fill plug with gasket in the **fluid fill** port.
 - d. Turn **ON** the pump and allow it to run for about 10 minutes.
 - e. Turn the pump **OFF** and refer to step 1 to drain the vacuum fluid.

4. Charge the pump with fluid as follows:
 - a. Reinstall the fluid-drain plug with flat gasket into the fluid-drain port.
 - b. Remove the fluid-fill cap and fill the pump to capacity with VPO-3000 vacuum pump fluid. Using other than VPO-3000 vacuum pump fluid may result in damage to the pump or compromise the pump performance and lifetime.
 - c. Reinstall the fluid-fill cap with flat gasket.

Long Term Storage (2 weeks or longer)

Before placing a pump in long term storage, follow the procedure below:

1. Drain all fluids from the pump as described in the previous section.
2. Refill the pump with clean VPO-3000 vacuum fluid as described in section for changing the pump fluid.
3. Always cover both the intake and exhaust ports with caps to keep any dust or foreign materials from entering the pump. Place pump in original container if available.
4. Be sure that the pump is stored in a horizontal position with the intake and exhaust ports facing up.
5. When putting a pump into storage, put a pin hole in both the intake and exhaust port caps.

Avoiding Oil Leaks During Shipping and Storage

Always drain your vacuum pump of all fluids before shipping. Failure to do so can result in damaged shipping containers and delays by freight carriers due to possibility of the presence of hazardous materials in the event of a spill.

TROUBLE SHOOTING

Symptom	Check	Steps to Take
Noisy motor, will not turn.	<p>Power line voltage and connections</p> <p>Any foreign materials inside the pump.</p> <p>Motor (open internal circuit).</p>	<p>Correct voltage or connections.</p> <p>Remove the foreign materials. If problem is with oil, change oil.</p> <p>Replace open windings.</p>
Noisy and hot pump.	<p>Any foreign materials inside the exhaust valve.</p> <p>Leakage in the system.</p> <p>If leakage, valve is open.</p> <p>All the valves in the vacuum line.</p>	<p>Remove foreign materials.</p> <p>Fix the leakage.</p> <p>Close the valve.</p> <p>Close if found open.</p>
Vacuum drops (gets worse).	<p>Oil level.</p> <p>Leakage on the device connected.</p> <p>Moisture content of oil.</p> <p>Oil regulator.</p> <p>If gas ballast is open.</p>	<p>Add oil.</p> <p>Close the intake and recheck.</p> <p>Change oil.</p> <p>Replace.</p> <p>Close the gas ballast.</p>
Motor runs, but not pump.	<p>Worn out coupling mechanism.</p> <p>Worn out key between motor and pump.</p>	<p>Replace coupling.</p> <p>Replace the key and the set screws.</p>

Model 100-3.5

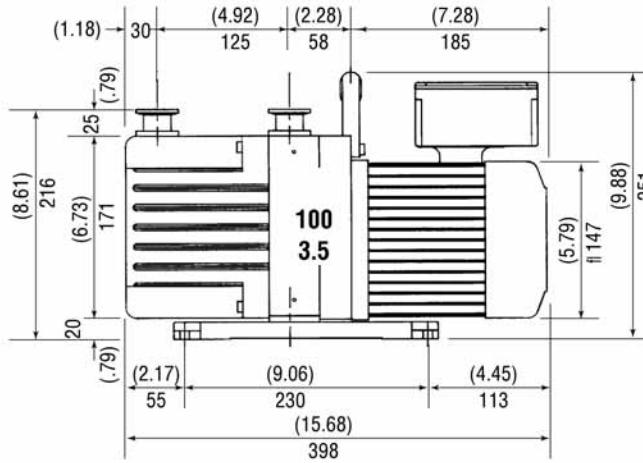
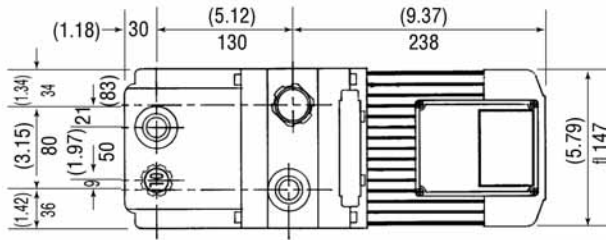

Model 200-7

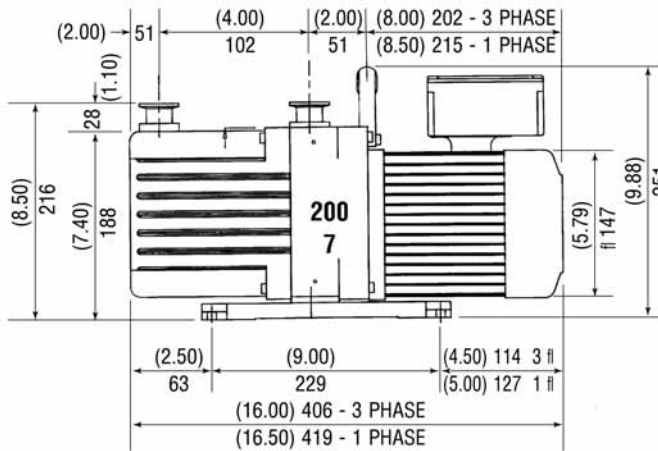
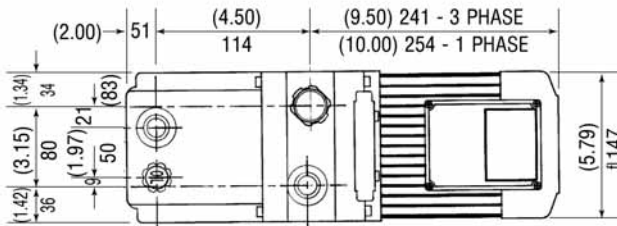

Model 400-14

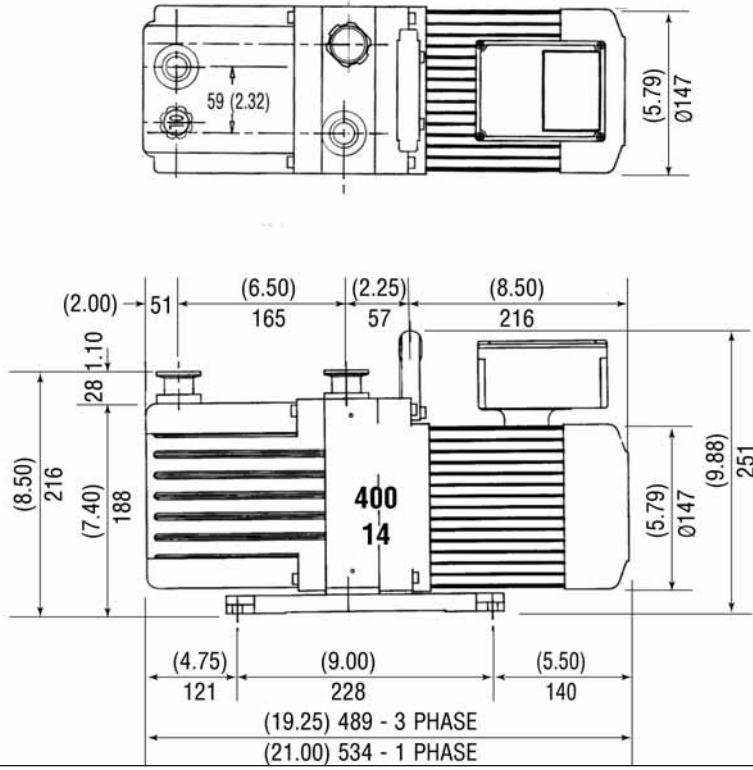

Model 600-21

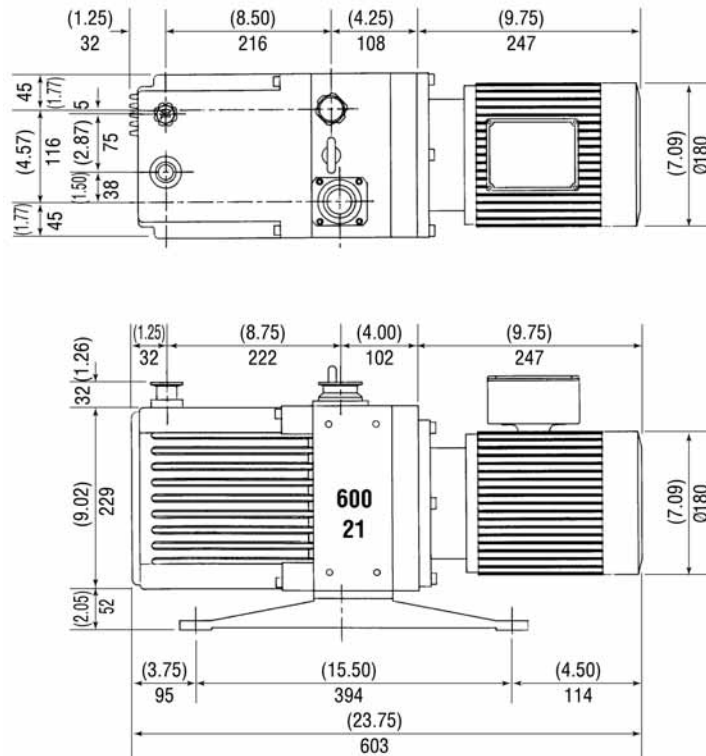

Model 800-28

