Operating Instructions

Digital Pressure Indicators

Dual Set Point Controllers

With Stainless Steel and Silicon Transducers

- **0 to 20 PSIG**
- **0 to 200 PSIG**
- **0 to 1000 PSIG**
- **0 to 2000 PSIG**
- **30" Hg to 100 PSIG**
- **30" Hg to 150 PSIG**
- **30" HG to 200 PSIG**

Contents

INTRODUCTION	1
Instruments Covered By This Manual	1
Indicator	2
Dual Set Point Controller	2
SPECIFICATIONS	3
INSTALLATION	5
Unpacking Instructions	5
Panel Mounting	6
Gauge Tube Installation	6
OPERATING INSTRUCTIONS	9
Readings On The Display	9
Setting the Control Points	10
Adjustment Knobs for Control Points - Optional	9
Control Point Hysteris Adjustment - Optional	10
Relay Output Connector Wiring	11
Analog Output Signal	12
Output Voltages	12
Optional 4-20 mA and 0-5 or 0-10 VDC Output	13
Calibration	14
Zero & Span Adjustment	14
0-20 and 200 PSIG Instruments	14
30 Inches Hg to 150 & 200 PSIG Instruments	14
Pressure Calibration	15
Cable Extensions	15
Transducer Wiring	15
Changing Operating Line Voltage	16
Return Shipment Procedure	16
WARRANTY AND RETURN PROCEDURE	17
PARTS AND ACCESSORIES	18
DIMENSION DRAWINGS	19

1. INTRODUCTION

The Pressure Gauge Indicator and Dual Set-Point Controller are compact pressure measurement and control instruments that offer the precision and high resolution of digital electronics at the same price as analog controls.

While the instruments are not completely immune to shock and vibration, they do not have a delicate analog meter and therefore are considerably more rugged than analog types.

1.1. Instruments Covered By This Manual

This manual covers the following instruments:

- **0 to 20 PSIG indicator**
- **0 to 20 PSIG Dual Set Point Controller**

- **0 to 200 PSIG indicator**
- **0 to 200 PSIG Dual Set Point Controller**

- **0 to 1000 PSIG indicator**
- **0 to 1000 PSIG Dual Set Point Controller**

- **0 to 2000 PSIG indicator**
- **0 to 2000 PSIG Dual Set Point Controller**

- **30 inches Hg Vacuum to 100 PSIG indicator**
- **30 inches Hg Vacuum to 100 PSIG Dual Set Point Controller**

- **30 inches Hg Vacuum to 150 PSIG indicator**
- **30 inches Hg Vacuum to 150 PSIG Dual Set Point Controller**

- **30 inches Hg Vacuum to 200 PSIG indicator**
- **30 inches Hg Vacuum to 200 PSIG Dual Set Point Controller**

1.2. Indicators

The indicator instruments are rugged, digital gauges. They are small, compact instruments that power the transducer and condition the output signal. Life expectancy for the transducer is excellent.

Your instrument is ready to operate as received. All that is needed to place the indicator in operation is installation of the transducer and instrument, connection of the transducer cable and plugging the line cord into an AC power outlet.

The instrument is powered from a 115 VAC or 230 VAC line as specified when ordering. Power consumption is about 1 Watt. Either 50 or 60 Hz power may be used.

A 10 foot long transducer cable is attached and extensions up to 500 feet (if using #18 wire) may be added without affecting calibration. See section on Cable Extensions for information.

1.4. Dual Set Point Controller

In addition to acting as a digital indicator, the Dual Set Point Controller instrument operates two control relays. Set point pressures are set from the front panel and displayed on the meter. Push-to-Set switches simplify display of the set points. Relays have 3 amp contacts, form C, and are terminated in screw terminal connectors on the rear. The mating half of the relay connector is provided.

The instrument is powered from a 115 VAC or 230 VAC line as specified when ordering. Power consumption is about 2 Watts. Either 50 or 60 Hz power may be used.

A 10 foot long gauge tube cable is attached and extensions up to 500 feet (if using #18 wire) may be added without affecting calibration. See section titled, "Cable Extensions" for more information.

Installation of the controller is identical to the Digital Indicator except for wiring the relay connectors for the control action. This is described in the section titled, "Relay Output Connector Wiring."

2. SPECIFICATIONS

- **Pressure Range: (Depending on Model)**
 - 0 to 20 PSIG
 - 0 TO 200 PSIG
 - 0 to 1000 PSIG
 - 0 to 2000 PSIG
 - 30 inches Hg Vacuum to 100 PSIG
 - 30 inches Hg Vacuum to 150 PSIG
 - 30 inches Hg Vacuum to 200 PSIG
- **Linearity:** $\pm 1/2\%$ Full Scale.
- **Sensitivity:** $\pm 0.1\%$ Full Scale Torr.
- **Response Time:** Less than 1 second for response to a step change.
- **Calibration:** Any gas, liquid or vacuum compatible.
- **Set Point Range:** Full scale, equal to full scale range of instrument.
- **Set Point Repeatability:** ± 2 digits.
- **Set Point Hysteresis:** Adjustable
- **Analog Output:** 0 to 2.00 volts into 2000 ohm load or higher; 2 pin connector included. 4-20 mA optional.
- **Transducers:** 1/4 inch NPT male thread standard; 1/8 inch NPT male pipe thread on all stainless steel transducers.
- **Power Consumption:** Approx. 1 Watt for indicator, less than 2 Watts for Controller.
- **Relays:** (Controller Only) Separate relays are provided for high and low set points. Each relay is SPDT with contacts rated 3 Amp @115 VAC; non-inductive. 3 pin screw terminal connectors are located on rear of instruments.
- **Line Power:** 115 VAC, 50/60 Hz; 230 VAC optional at no additional cost.
- **Line Regulation:** $\pm 20\%$ change in line voltage produces less than 1% change in reading.

- **Temperature Effects:** When changes occur in ambient temperature between 0°C and 50 °C reading will change no more than $\pm 0.02\%$ per °C.
- **Dimensions:** See drawings at back of manual.
- **Mounting:** Panel mounting hardware is included. Bench mount cabinet and 1/4 DIN bezel optional
- **Transducer Cables:** 10 foot (305 cm) attached.
- **Extension Cables:** Change sensor cable length without recalibration. Extensions to 500 feet (150M) can be used.
- **Line Cord:** 3 wire 5 1/2 feet (170 cm) long.
- **Net Weight:** Indicator 1 lb., 2 oz. (0.5 kgs); Controller 1 lb., 6 oz.
- **Shipping Weight:** Indicator 2 lbs., 8 oz. (1.1 kg); Controller: 3 lbs. (1.3 kg).

3. INSTALLATION

3.1. Unpacking Instructions

The instruments and gauge tubes are carefully packaged to protect them during shipment. Use reasonable care when removing them from the shipping box.

Inspect the instruments and gauge tubes carefully when you receive them. Should either the instruments or the gauge tubes show any signs of damage, file a claim with the carrier immediately. Do not destroy the shipping container. It will be required by the carrier as evidence to support claims. Call the factory immediately for instructions on return and repair of the instruments.

Please fill out and return the Warranty Registration card so that we can register your instrument in our warranty records.

3.2. Panel Mounting

Both the digital indicators and dual set-point controllers mount in a single panel cut out. Instruments provided in “standard enclosures” fit the same 2.75” (70 mm) round hole as used by Hastings, Televac, Lesker, Varian and other analog meter instruments. A ‘U’ shaped panel mounting clip is included with the instrument. Instruments provided in 1/4 DIN Enclosures fit a 92 mm X 92 mm cut out. Jack screws are included with 1/4 DIN instruments.

1. Loosen the screws and remove the ‘U’ shaped bracket from the standard enclosure or the 2 jack screws from the sides of the 1/4 DIN enclosure. Feed the power and gauge tube cables through the panel cutout and hold the instrument flush against the panel.

2. Reinstall the ‘U’ clip or jack screws. Lightly tighten (finger tight) the jack screws against back of the panel.

3. Adjust the front panel of the instrument to be square and level and tighten jackscrews snugly. Do not over-tighten.

4. Connect the power cord to an AC line power outlet of the appropriate voltage. Power consumption is approximately 2 watts.

5. Unless tagged, the instrument is shipped ready for operation on 115 VAC. If modified at the factory for 230/240 volt use, the 115 volt connector will be removed and the instrument tagged or marked for 230 volt operation. The customer will then be required to wire the power cord to his connector as follows:

Black = Line White = Neutral Green = Ground

6. After the gauge tube is installed in the vacuum system, connect the gauge tube cable to the gauge tube (See the following section, “Gauge Tube installation”, for more information on installing the gauge tube).

7. For controllers, please refer to the section titled, “Relay Output Connector Wiring” for information on connecting the output relays. Information on connecting the analog output signal for both the indicator and the controller instruments is contained in the section titled, “Analog Output Signal”.

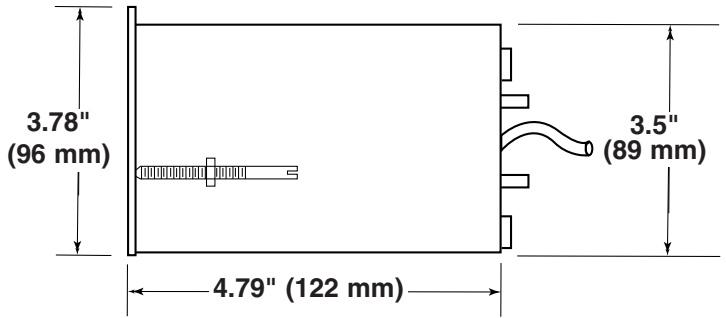

1/4 DIN Enclosure

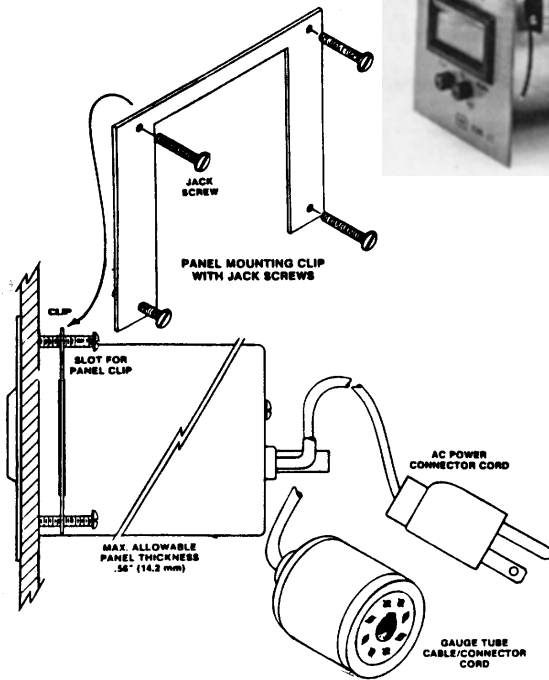
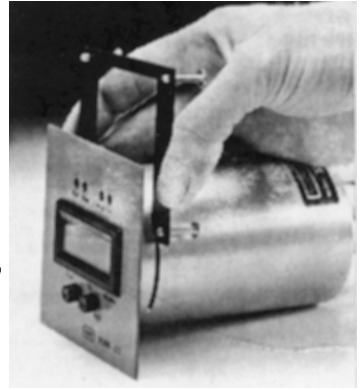

Standard Mounting With Clip

3.3. Transducer Installation

1. Thread the transducer into a 1/4 inch NPT female fitting (or other fitting or flange as per your transducer), in the vacuum system. The preferred mounting is with the open end pointing down so as to be self draining to any condensation. However, mounting in any position is acceptable.

2. An appropriate thread sealant is required to insure that the threaded connection will not leak. Teflon thread tape may be used to seal the threads if care is used so it will not shred off and get inside the tube or vacuum system. It is better to use mini-seal or an epoxy sealer on the threads.

4. OPERATING INSTRUCTIONS

4.1. Readings On The Display

When the power is applied and the gauge tube connection is made, your instrument is in operation. After a short time period for stabilization, the digital display will show a reading of vacuum pressure.

At atmospheric pressure, and at any pressures above the designed range of the instruments, the display will show a "1" with the other digits blanked out.

When the pressure drops to be within the designed pressure range of the instrument the display will function normally.

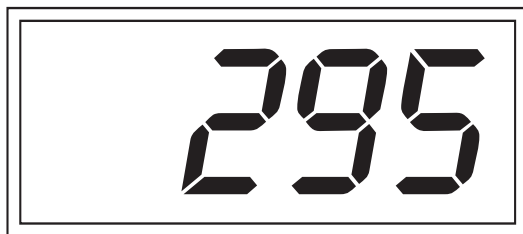

Normal Display

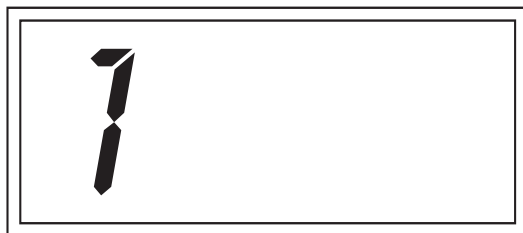

Typical display when pressure too high to read; above the range of the instrument

4.2. Setting the Control Points

To set the control points, press in either the Low or High “Push To Display” push-button on the front panel. This will display that set point on the digital meter. Adjust the multi-turn pot that corresponds to that set point until the desired pressure for the control action is read on the meter. The set point adjustment pots are located on the front panel on either side of the LEDs. Release the “Push To Display” push-button and the instrument will again read pressure.

If the meter saturates and reads 1 xxx with the right-most digits (xxx) blanked out, the control pressure setting is still correctly displayed when either of the push-buttons are depressed.

The LED’s show control action in the following manner:

- Relay energized, LED is ON ;de-energized, LED is OFF
- Relays are de-energized when pressure is above the set-point (on atmospheric pressure side of set point)
- Atmospheric pressure = de-energized = loss of power
- “NORMAL” = de-energized relay
- No Power = in no power state relays are de-energized

4.2.1 Relay Output Connector Wiring

Recessed screwdriver adjustment potentiometers are standard, but front panel knobs can be provided instead.

Note that these knobs can only be provided when the optional 1/4 DIN case is used.

4.2.2 Control Point Hysterisis Adjustment Optional

Certain process control systems will work better if the control point hysteresis can be adjusted, and this feature can be provided on instruments built in the optional 1/4 DIN case. When this option is selected two front panel screw driver adjustable switches are provided: one for

the low and one for the high control point. These allow the selection of hysteresis of 2(1), 4(2), 6(3), 8(4), or 10(5) meter digits. When using this feature keep in mind that the control point displayed is the middle of the hysteresis value. For example, a control point of 1125 Torr with a hysteresis of 10(5) will cause the relays to change state at 1120 and 1130 Torr.

4.3. Relay Output Connector Wiring

Contact Rating:

- 3 amps, 120 VAC, resistive
- 1.5 amp, 230 VAC, resistive
- 1.5 amp, 28 VDC, inductive

Gently pull the connectors and they will detach from their sockets for wiring. Plug back in when connections are made. The “Low” set point relay is on the right side when looking at the instrument from the rear.

Relay Connectors On Rear Of Controller

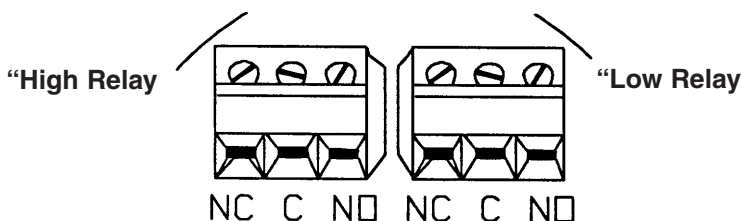

4.4. Analog Output Signal

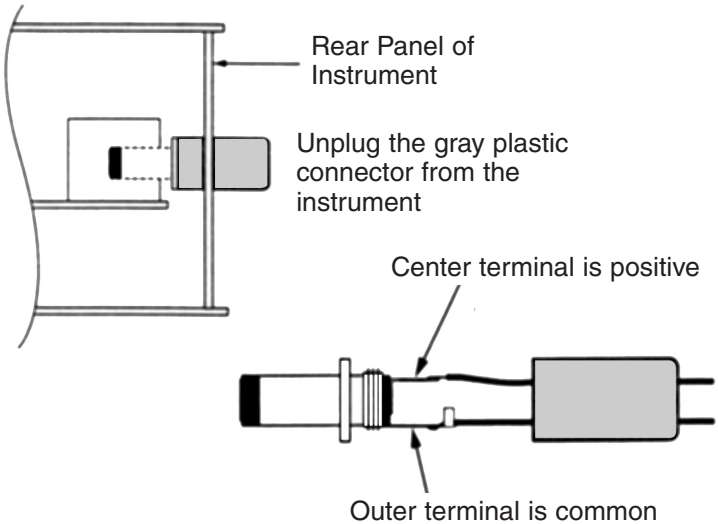

Gauges are shipped with a removable connector for analog output plugged into the rear panel of the instrument. Follow the steps below to wire the connector for output to remote recorders, dataloggers, etc.

1. Unplug the gray connector from the rear panel.
2. Unscrew the gray plastic connector cover.
3. Feed your analog output wires through this cover.
4. Solder the positive wire to the center terminal.
5. Solder the common or negative wire to the outer terminal.
6. Reinstall the connector cover and plug into the gauge.

4.4.1 Instruments Covered By This Manual

0 to 20 PSIG, 0 to 200 PSIG, 0 to 2000 PSIG

Output: 0 to 2.000 Volt DC

0 to 1000 PSIG

Output: 0 to 1.000 Volt DC

30 Inches Hg Vacuum to 100 PSIG

Output: -300 Volt to 0 to 1.00 Volt DC

30 Inches Hg Vacuum to 150 PSIG

Output: -300 Volt to 0 to 1.50 Volt DC

30 Inches Hg Vacuum to 200 PSIG

Output: -300 Volt to 0 to 2.00 Volt DC

4.4.1 | Optional 4-20 mA & 0-5 or 0-10 VDC Output

Gauges provided with an optional output are built in 1/4 DIN size cabinets which mount in 92 mm square panel cut-outs.

On the rear panel of the instrument you will find a section identified as “analog output” which includes the zero and span adjustment potentiometers and a male connector similar to the standard output connector for the 4-20 mA, 0-5 or 0-10 VDC outputs.

Unplug this connector and unscrew the gray plastic shroud. Feed a shielded wire through this shroud and solder the shield to the outside lug and the center conductor to the inner lug. The shield is the circuit common or zero and the center conductor is 20 mA, 5 or 10 volts. The output is floating. The resistance in the mA output loop can be up to 1000 ohms. The 5 or 10 VDC output should have loads of 2000 ohms or higher.

Before being shipped from the factory the 4 mA is scaled to the low end of the instrument range (or zero pressure) and the 20 mA is adjusted to coincide with the full scale instrument reading of 100 mTorr, 2000 mT, 20.00 Torr or 1500 Torr. Instruments built with 5 or 10 VDC outputs are also scaled before shipping. Rear panel zero and span adjustments are provided with all output ranges should fine tuning in the field be required.

The standard analog output voltage signal described in section 4.4 of the manual continues to function even when these optional outputs are provided.

4.5. Calibration

There are only 2 calibration adjustments that are normally necessary to re-standardize the instrument.

One is a “zero” adjustment for hard vacuum and the second is a span adjustment to set up scale tracking at some known pressure.

The adjustment pots are located on the rear of both the indicator and controller instruments. The pots are clearly marked .

Plug in the power cord of the instrument and “warm up” the instrument for at least 30 minutes.

4.5.1 Zero & Span Adjustment

0 - 20, 200, 1000 and 2000 PSIG Instruments

Zero adjustment is made by exposing the transducer to atmospheric pressure and setting the “offset” pot on the rear of the instrument to read 000 on the meter. The transducer should be mounted open end down (factory adj.) or in the position in which it is used. Upscale adjustments are made at 60 to 80% scale pressure using the span pot. Use a 1/4 % or better pressure gauge as a reference.

30 Inches Hg to 100, 150 & 200 PSIG Instruments

1. Adjust “offset” for zero as above.
2. Adjust the vacuum side first. Pump the transducer to a vacuum that is at least 2 mm Hg (Torr) absolute or lower. It need not be known as long as it is less than the 2 mm Hg. Obtain the correct barometric pressure and adjust the pot marked “span” to read the barometric pressure. To obtain the correct barometric pressure call the “FAA Pilot One Call Briefing” line at our local airport. Ask for the Station pressure, not the altimeter reading.

Pressure Calibration

Install the transducer in a pressure system that has an accurate pressure gauge as a reference (1/4 % or better). Raise the pressure to 60 PSIG. Remove the 2 screws in the rear and slide the cover back. Adjust the trim pot on the piggy-back PC board until the instrument reads 60.0 on the meter.

If your reference is a dial gauge, tap it to eliminate hysteresis. Repeat adjustments if necessary. Do not adjust zero unless you are sure the system is open to atmosphere.

Zero adjustment is made the same as described above for the pressure only instruments.

4.6. Transducer Wiring

The indicator and controller models are unique in their ability to change cable lengths without requiring recalibration.

4.7. Transducer Wiring

The indicator tube can be checked with an ohmmeter between pins 1 and 5 to verify that the sensor is good. Generally, the reading is less than 2.5 ohms if good; 900 ohms if the sensor is broken.

Six wires are used on the transducer:
Pins: 1, 4, 5, 6, 7 & 8.

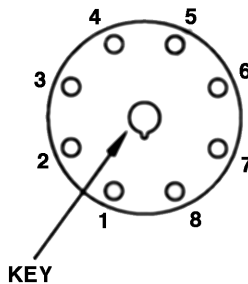

4.8 Changing Operating Line Voltage

The operating voltage for instruments can be changed in the field by changing the connection across four pads on one of the circuit boards. For access to these pads, remove 2 screws in rear of the cylindrical outer cover. Slide the cover back, completely away from the circuit boards. Locate the four pads on the edge of the circuit board where the power cord comes to the circuit board.

Instruments set for operation at 115 VAC have jumpers connecting the outside pairs of the four pads. Instruments set for operation at 220 VAC have jumpers connecting the inside pair of the four pads. See illustration below.

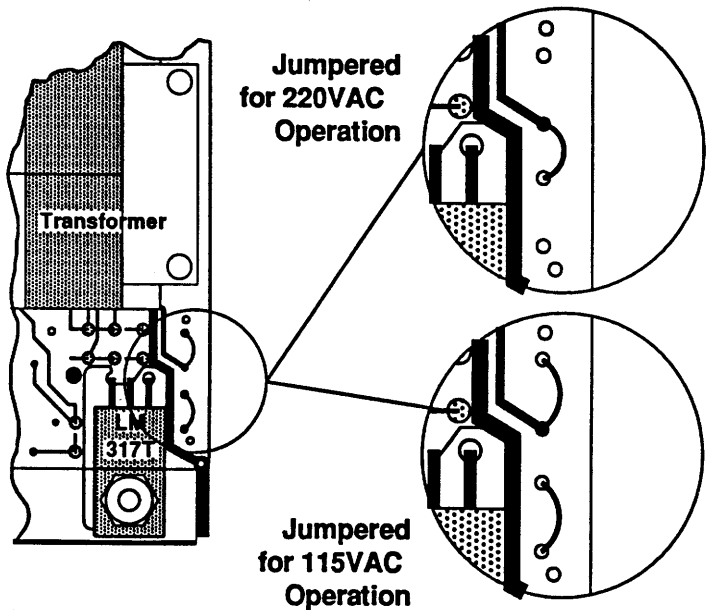

Clip the jumpers close to the pads and install new jumper(s) to change to the desired configuration.

4.9 Return Shipment Procedure

If repairs are required, return the instrument with cables and gauge tube to the manufacturer, pre-paid. Include a purchase order and statement of the nature of the problem.

4.8. WARRANTY STATEMENT

The manufacturer warrants all instruments for a period of two years against defects of material and workmanship subject to the terms and conditions set forth below:

1. The warranty is in effect at date of shipment from the manufacturer to the original purchaser.
2. Expendables such as gauge tubes, etc. are not covered by this warranty.
3. Claims against this warranty for replacement parts and/or service shall be limited to defects in materials and workmanship. Malfunctions attributable to neglect, abuse, or repair and operational procedures not specifically recommended by the manufacturer are not warranted.
4. Service repairs and/or piece part replacement shall be warranted for a period of ninety (90) days commencing on date of return shipment or until expiration of the remaining term of original instrument warranty, whichever is later.
5. The manufacturer shall not be liable for consequential damages nor for labor, loss or expenses directly or indirectly arising from use of their products or equipment.
6. This warranty does not apply to shipping damage. Claims for damage incurred while products are in transit rest with purchaser. Said claims are to be levied against the carrier.
7. Amendments, assumed corollaries or statements contrary to the terms of this warranty shall not be binding upon the manufacturer unless stated in writing and approved by an officer of the manufacturer.

8. THE MANUFACTURER MAKES NO OTHER WARRANTY, EXPRESSED OR IMPLIED, AND MAKES NO WARRANTY OF MERCHANTABILITY OR OF FITNESS FOR ANY PARTICULAR PURPOSE.

9. Warranty service is F.O.B. point of manufacture. All transportation charges to and from the manufacturer's plant shall be the responsibility of the purchase

6. PARTS AND ACCESSORIES

Gauges and Controllers

0.01 - 100 mTorr Dual Set Point Controller.....	902005
0.01 - 100 mTorr Indicator.....	902006
1 - 2000 mTorr Dual Set Point Controller.....	902001
1 - 2000 mTorr Indicator.....	902002
1 - 2000 mTorr Portable, Battery Powered Indicator.....	902017
0.01 - 20 Torr Dual Set Point Controller.....	902015
0.01 - 20 Torr Indicator.....	902016
1 mTorr- 20 Torr Dual Range Indicator.....	902025
1 - 1500 Torr Dual Set Point Controller (± 1 Torr).....	902019
1 - 1500 Torr Indicator (± 1 Torr).....	902020
30" Hg - 100 PSIG Dual Set Point Controller.....	904001
30" Hg - 100 PSIG Indicator.....	904002
.01 - 20 PSIG Dual Set Point Controller.....	904005
.01 - 20 PSIG Indicator.....	904006
.01 - 200 PSIG Dual Set Point Controller.....	904003
.01 - 200 PSIG Indicator.....	904004

Gauge Tubes, Sensors, and Accessories

0.01 to 100mTorr Gauge Tube 3/4"OD Tubulation.....	912018
0.01 to 100 mTorr Gauge Tube KF Flange	912037
0.01 to 100 mTorr Gauge Tube, 1.33 in Conflat, non-rotatable	912160
0.01 to 100 mTorr Gauge Tube, 2.75 in Conflat, non-rotatable.....	912038
0.01 to 100 mTorr Gauge Tube, 15 mm Diameter Tube	912101
1 to 2000 mTorr Gauge Tube with 1/8 in. NPT Male Thread.....	912001
1 to 2000 mTorr Gauge Tube with KF-16 Flange	912005
1 to 2000 mTorr Gauge Tube with 1.33 in Conflat, non-rotatable....	912067
1 to 2000 mTorr Gauge Tube with VCR-4 Fitting.....	912068
1 to 2000 mTorr Gauge Tube, 15 mm Diameter Tube.....	912102
1 to 20 Torr Gauge Tube with 1/8 in. NPT Male Thread.....	912011
1 to 20 Torr Gauge Tube with KF-16 Flange	912072
1 to 20 Torr Gauge Tube with 1.33 in Conflat, non-rotatable.....	912073
1 to 20 Torr Gauge Tube with VCR-4 Fitting.....	912074
1 to 20 Torr Gauge Tube, 15 mm Diameter Tube.....	912103
All Stainless Steel Gauge Tubes for outdoor applications or wherever the use 304 SS is appropriate. All wetted parts as well as an external parts and connector pins are 304 SS. . . Add "SS" prefix to any tube P/N.	
Extension Cable with Connectors for All Tubes (not wide range)....	912063
3 Position Gauge Tube Selector.....	902027
Gauge Tube Baffle, Brass 1/8 NPT.....	912007
1 - 2000 mTorr Vacuum Gauge Calibrator.....	902008
.01 - 20 Torr Vacuum Gauge Calibrator.....	912009
100 mTorr Vacuum Gauge Calibrator.....	912019
Single Bench Mount Cabinet (fits instruments of any span).....	V805002
Double Bench Mount Cabinet (accommodates 2 instruments or instrument & 3 pos. selector.....	V805003
1/4 DIN Bezel Kit (for 92 mm DIN cutout, fits any instrument).....	V805004
Handle for Bench Mount Cabinet.....	V805005
Lined Carry Case for Portable Gauge.....	912028

7. DIMENSION DRAWINGS

Panel cut-out dimensions

for indicator, Dual Set-Point Controller,
and 3-Position Switch in Standard Enclosure

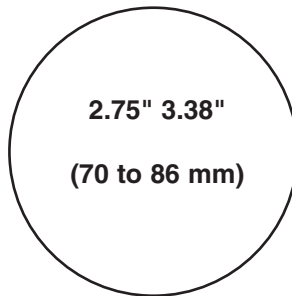
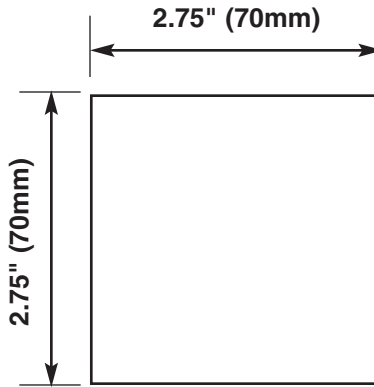

92 mm square cut-out is standard 1.4 DIN.
The DIN bezel adapter fits this cut-out. Bezel
adapter may also be used for appearance with
either of the above cut-outs.

Indicators Are Available in 2 Enclosure Styles

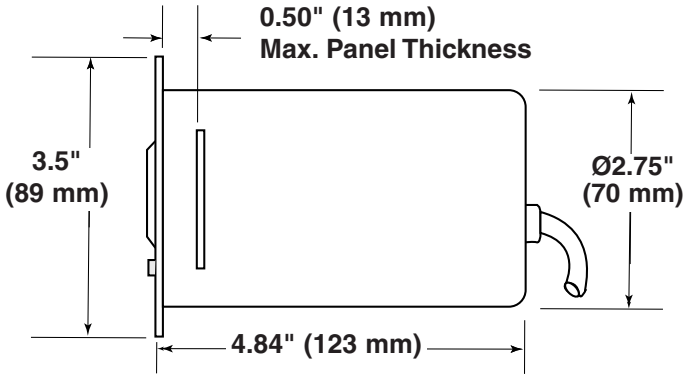

Standard Enclosure

The standard enclosure has a cylindrical body that fits the same 2.8 inch diameter panel cutout as Hastings, Televac, and other gauges. Panel mounting hardware is included with standard enclosure.

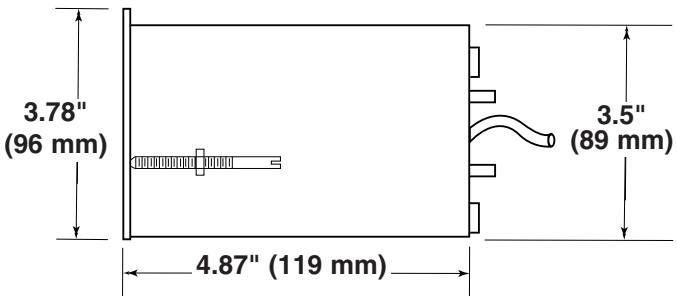

1/4 DIN Enclosure

The 1/4 DIN enclosure is rectangular and fits the standard 92mm x 92mm panel cutout. Panel mounting jackscrew are included with 1/4 DIN enclosure.

Dual Set Point Controllers Are Available in 2 Enclosure Styles

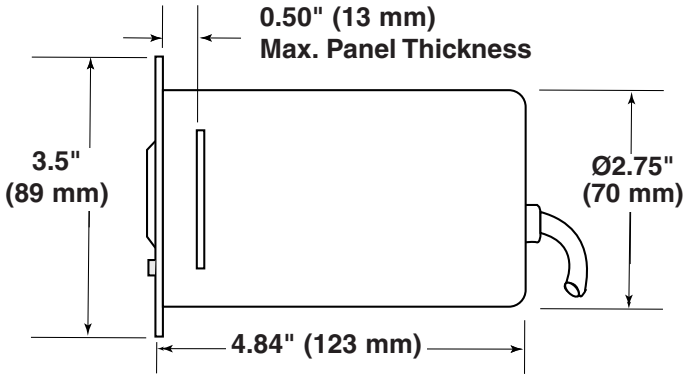

Standard Enclosure

The standard enclosure has a cylindrical body that fits the same 2.8 inch diameter panel cutout as Hastings, Televac, and other gauges. Panel mounting hardware is included with standard enclosure.

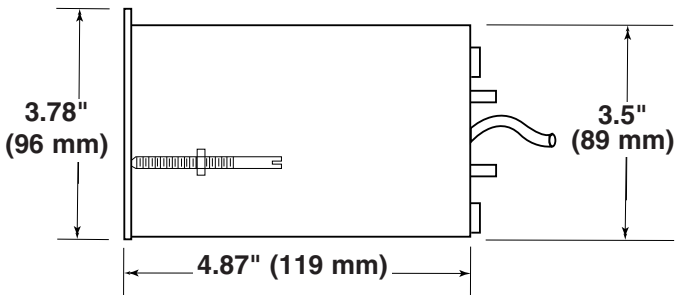

1/4 DIN Enclosure

The 1/4 DIN enclosure is rectangular and fits the standard 92mm x 92mm panel cutout. Panel mounting jackscrew are included with 1/4 DIN enclosure.

Vacuum Research Corp. • 2419 Smallman Street • Pittsburgh, PA 15222 USA
Phone: (800) 426-9340 • (412) 261-7630 • FAX: (412) 261-7220
e-mail: VRC@vacuumresearch.com

Rev. May, 2008